

# Office Paper Recycling Bin:

*For maximum resource recovery*



- EASY HANDLING
- DURABLE CONSTRUCTION
- ENVIRONMENTALLY RESPONSIBLE



## Removable Waste Holder

- Fits neatly in place
- Simplifies daily waste disposal
- Optional bin liner easily fitted
- Ensures high quality paper recovery through lower contamination



## Handles

- Moulded in handles for comfort
- Easy to carry for convenient use



## Benefits

- Compact shape fits neatly under desk
- Provides for source separation of high quality paper
- Eliminates the need for 2 or more bins

## Material

### OUTER BIN

- **Polymer components:**
  - Injection moulded from specially designed PP
  - Resistant to decay, frost, heat and chemicals
  - Special UV stabilisers provide excellent ageing characteristics
- **Long service life:**
  - High quality materials
  - Most advanced manufacturing processes
- **Recycling:**
  - Minimum of 30% recycled content used in manufacturing
  - All container parts are 100% recyclable

### INNER BIN

- **Polymer components:**
  - Injection moulded from specially designed HDPE
  - Resistant to decay, frost, heat and chemicals
  - Special UV stabilisers provide excellent ageing characteristics
- **Long service life:**
  - High quality materials
  - Most advanced manufacturing processes
- **Recycling:**
  - All container parts are 100% recyclable

## Design

### ADVANTAGES FOR THE USER:

- **Easy handling:**
  - Practical handle for effortless emptying
  - Light weight for easy movement
  - Space saving for convenient use
  - Eliminates the need for 2 or more bins
  - Inner bin slots in place and easily lifts out for hygienic emptying
  - Reduces contamination of recyclables
  - Maximises paper recycling
  - Waterproof, easily cleaned

## Colours

- Special colours including corporate colours for both outer and inner bins are available on request\*
- Standard colours:
  - Outer bin: Black
  - Inner bin: Red, Black, Orange, Burgundy



\*Minimum batch quantities required

## Quality

- Constant quality control through manufacturers laboratory

## Dimensions - Weights - Standards

- Nominal volume: Outer bin 13.5 litres
- Nominal volume: Inner bin 8.5 litres
- Net weight: 1.3kg
- Permitted total weight: 7.5 kg

Measurements to be used as a guide only - variations will occur

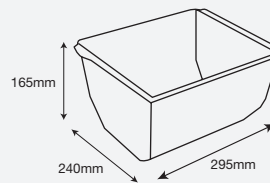
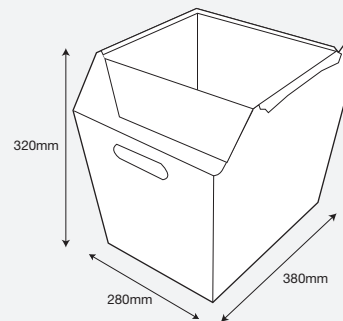

## Imprints and markings

- Individual markings with imprints or adhesive labels are available on request



# SULO®

## Resource Recovery

**BACK TO  
INDEX**