

# 1100 Litre Domed Container

*Second generation, first class*



- UNIQUE DESIGN
- EASY HANDLING
- IMPROVED SAFETY



## Safety Handles

- Easy grip handles on all sides
- Optimum manoeuvrability
- Compatible with identification and weighing systems



## Safety Trunnion

- Increased stability
- Increased safety when lifting



## Optional Safety Lid in Lid

- Easy and safe handling
- Simple hinged "lid within a lid"
- Prevents depositing of bulky waste

## Material

- **Polymer components:**
  - Injection moulded from specially designed HDPE
  - Resistant to decay, frost, heat and chemicals
  - Special UV-stabilisers provide excellent ageing characteristics
- **Corrosion resistant steel components**
- **Noise reduction:**
  - Wheel assemblies with solid rubber tyres
- **Long service life:**
  - High quality materials
  - Excellent manufacturing processes
  - Withstands exposure to high mechanical stress levels
- **Recycling:**
  - All container parts are recyclable

## Design

### ADVANTAGES FOR THE USER:

- Easy to use lid, lockable, with adjustable spring support system
- High degree of safety - integrated child safety device prevents accidental closing of lid
- Versatile, with a comprehensive accessories range
- Easy grip handles on all sides
- Safe, easy handling, even with heavy loads
- Wide lifting trunnions for improved safety during lifting, even with awkward loads
- Various wheel assembly configurations for different applications
- Water drainage plug as standard†
- Compatible with identification and weighing systems
- Domed lid with unique opening mechanism reduces wind problems during emptying
- Easy to clean due to smooth surfaces and rounded internal surfaces
- Reinforced base, front and rear panels for greater stability

## Accessories

- For accessories and special design variations such as lid apertures, locks and towing brackets, **please click here**

## Colours

- Standard colours: green, red, yellow, blue
- Special colours are available on request\*
- Lid and body colours can be mixed and matched
- All additives are cadmium free and environmentally friendly



\*Minimum batch quantities required

## Quality

- Certified to AS 4123, DIN EN 840 and RAL GZ 951/1
- Constant quality control through manufacturers laboratory as well as independent institutes



Note: Certification and Quality Marks depicted in this brochure are registered to SULO Umwelttechnik GmbH & Co. KG

## Dimensions - Weights - Standards

- Nominal volume: 1100 litres
- Net weight: approx. 65 kg
- Max. load: 440 kg
- Permitted total weight: 510 kg

Measurements to be used as a guide only - variations will occur

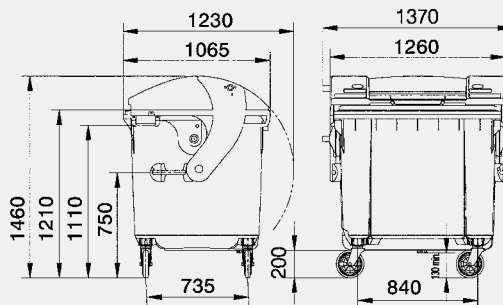

## Imprints and markings

- Manufacturer, year of manufacture, material
- Nominal volume, max. permitted total weight EN 840, RAL markings
- Individual markings with imprints, hot-foil printing or adhesive labels available on request\*



# SULO®

## 4-Wheeled Container Systems

**BACK TO  
INDEX**