

# 660 Litre Container

*A fresh look at an old favourite*



- EASY HANDLING
- MAXIMUM SAFETY
- ATTRACTIVE DESIGN



### Easy handling

- Easy grip handles on all sides
- For easy filling
- For safe manoeuvring
- Compatible with identification and weighing systems



### Improved design features

- Ensures stability even when fully loaded
- Very stable wheel assemblies
- Reinforced base, front and rear panels for greater stability



### Maximum safety

- User friendly
- Foot pedals on the front wheels lock the bin in position
- Directional locks are ideal for use with towing equipment

## Material

- **Polymer components:**
  - Injection moulded from specially designed HDPE
  - Resistant to decay, frost, heat and chemicals
  - Special UV-stabilisers provide excellent ageing characteristics
- **Corrosion resistant steel components**
- **Noise reduction:**
  - Quiet-running tyres
- **Long service life:**
  - High quality materials
  - Most advanced manufacturing processes
  - Withstands exposure to high mechanical stress levels
- **Recycling:**
  - All container parts are recyclable

## Design

### ADVANTAGES FOR THE USER:

- Easy handling, even with heavy loads
- Easy grip handles on all sides
- Stable and light weight lid
- User-friendly design
- Various wheel assembly configurations for different applications
- Water drainage plug as standard†
- Compatible with identification and weighing systems
- Suitable for all lifting equipment in accordance with EN 840
- Easy to clean due to smooth and rounded internal corners
- Rounded lid profile for improved rainwater dispersal
- Fitted as standard with chip nest in accordance with RAL GZ 951/1
- Reinforced base, front and rear panels for greater stability

## Accessories

- For accessories and special design variations such as lid apertures, locks and towing brackets, **please click here**

## Colours

- Standard colours: green, red, yellow, blue
- Special colours are available on request\*
- Lid and body colours can be mixed and matched
- All additives are cadmium free and environmentally friendly



\*Minimum quantities required

## Quality

- Certified to AS 4123, DIN EN 840 and RAL GZ 951/1
- Constant quality control through manufacturers laboratory as well as independent institutes



Note: Certification and Quality Marks depicted in this brochure are registered to SULO Umwelttechnik GmbH & Co. KG

## Dimensions - Weights - Standards

- Nominal volume: 660 litres
- Net weight: 43 kg
- Max. load: 265 kg
- Permitted total weight: 310 kg

Measurements to be used as a guide only - variations will occur

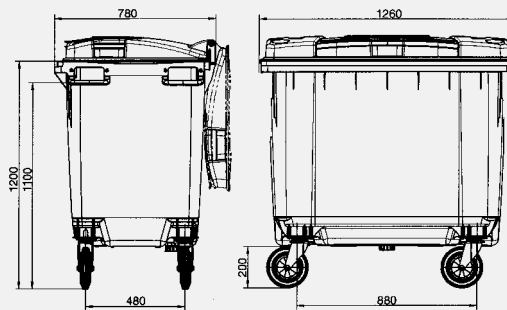

## Imprints and markings

- Manufacturer, year of manufacture, material
- Nominal volume, max. permitted total weight
- "No hot ashes" symbol
- EN 840, RAL markings
- Individual markings with imprints, hot-foil printing or adhesive labels available on request\*



# SULO®

## 4-Wheeled Container Systems

**BACK TO  
INDEX**