

360 Litre Kompakt Container:

Increase your capacity to recycle



SPECIFICALLY DESIGNED TO SUIT AUSTRALIAN CONDITIONS AND LIFTING SYSTEMS



Designed for local market

- Unique design to suit rear and side Australian lifters[#]
- Increased capacity in a compact foot print
- Manufactured in accordance with AS4123
- Dimensions of lifting zone similar to a 240 litre



Multiple applications

- Ideal for increased recycling needs
- Part of a multi bin system approach
- Assists in achieving waste minimisation goals
- Increased capacity aids in preventing leakage into the waste stream

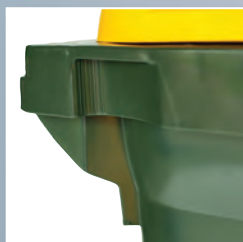

Improved design features

- Front hand grips for easy manoeuvring from all angles
- Textured finish on lifting columns for increased grip
- Foot step at rear aids in tilting the bin
- Easy grip handles for maximum comfort

Material

- **Polymer components:**
 - Injection moulded from specially designed HDPE
 - Resistant to decay, frost, heat and chemicals
 - Special UV-stabilisation provides excellent ageing characteristics
- **Corrosion resistant steel axle**
- **Noise reduction:**
 - Quiet-running solid rubber tyres
 - Tight-fitting axle
- **Long service life:**
 - High quality materials
 - Most advanced manufacturing processes
 - Withstands exposure to high mechanical stress levels
- **Recycling:**
 - All container parts are recyclable

Advantages

- Unique design to suit Australian market
- Textured lifting columns improve grip during lifting
- Rear foot step assists in tilting the bin for easy manoeuvring
- Unique hand grips allow for easy handling
- Ergonomic new look lid features optional ventilation
- Large area for customisation on both the body and lid
- Compatible with standard SULO components
- Dual axle housing provides maximum strength
- Compatible with identification and weighing systems
- Larger 250mm wheel for improved stability and easy handling
- Complies with performance standards of AS 4123.5, 6 & 7

Imprints and markings

- Manufacturer, year of manufacture, material
- Nominal volume, max permitted total weight
- No hot ashes or liquids standard lid insert
- Individual markings with imprints, multi colour print, hot-foil printing or adhesive labels*
- Laser marked unique ID and 2D Barcode
- Customer specific serial numbers if required*

Accessories

- For accessories and special design variations such as lid apertures and locks, **please click here**

Colours

- Standard colours: black, nature green, dark green, grey
- Non standard colours: red, yellow, blue, lime green*
- Additional colours available upon request, minimum order quantities apply



* Lime green available for lids only

*Minimum batch quantities required

#Suits most commercially available 240L lifters

Quality

- Manufactured in accordance with AS4123 and EN840



Dimensions - Weights - Standards

- Nominal volume: 360 litres
 - Net weight: approx 17 kg
 - Max load: 144 kg
 - Permitted total weight: 159 kg
-
- A 1100 mm ■ D 848 mm ■ G 650 mm
 - B 1028 mm ■ E 680 mm
 - C 770 mm ■ F 520 mm

Measurements to be used as a guide only – variations will occur

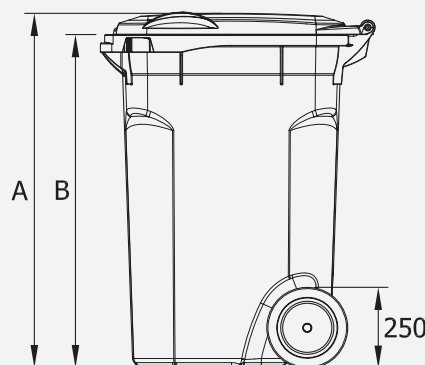
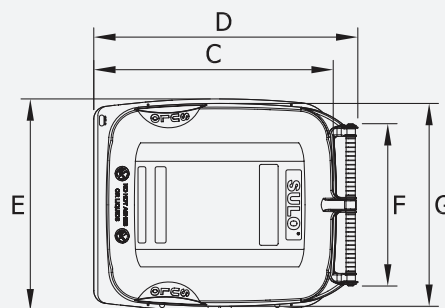

SULO
 2-Wheeled
 Container Systems

**BACK TO
INDEX**